

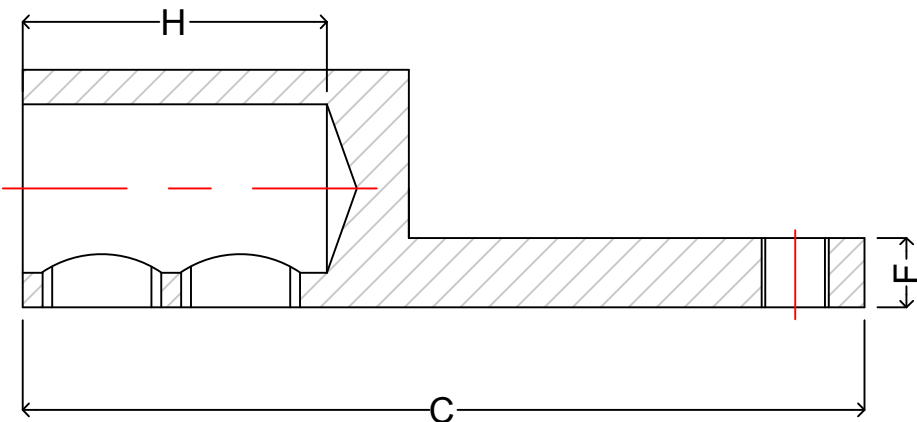

SPECIFICATION

A	B	C	D	E	F	G	H	I	J
ROD SIZE	ROD SIZE	TOTAL LENGTH	HEAD LENGTH	STEP LENGTH	STEP LENGTH	HOLE DIAMETER	HOLE DEEP	FITTING THREAD	THREAD (X2)
8.00	6.50	30.00	14.00	16.00	6.00	5.50	12.00	M 4	M 4
12.00	10.00	42.50	19.50	23.00	7.00	8.50	16.50	M 4	M 6

DRAWING

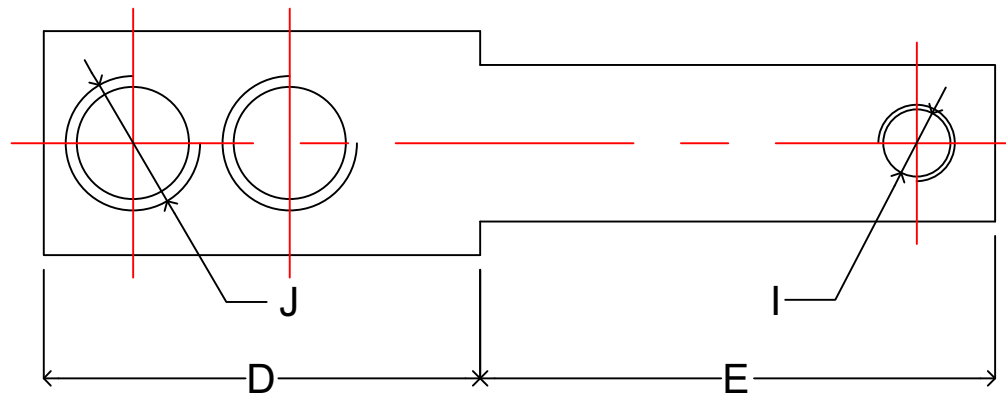
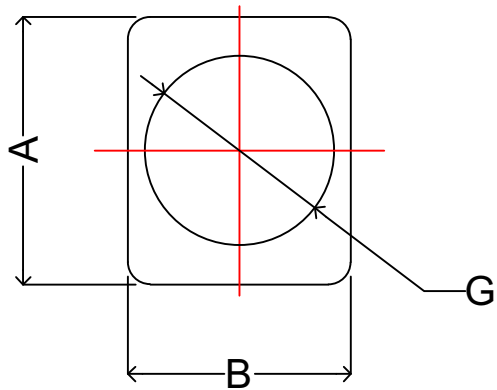

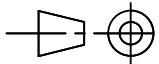
 SHREE GANGA™ ENTERPRISE An ISO 9001:2015 Certified Co.		TOLERANCE UNLESS OTHERWISE STATED	± 0.2 ANGLE ± 0'10'
HEAT TREATMENT			UNIT
NA			MM
MATERIAL		DATE	QTY.
High Grade Free Cutting Brass		06.08.2020	
TITLE		DRG. NO.	
Brass Energy Meter Parts		SG 1051	
		SCALE	SHEET 1 OF 1
		1 : 1	